

ARTICLE

Methods, Tools, and Technologies

PopEquus: A predictive modeling tool to support management decisions for free-roaming horse populations

Brian Folt¹  | Kathryn A. Schoenecker¹  | L. Stefan Ekernas² |
David R. Edmunds¹  | Mark Hannon¹

¹U.S. Geological Survey, Fort Collins Science Center, Fort Collins, Colorado, USA

²The Denver Zoological Society, Denver, Colorado, USA

Correspondence

Brian Folt
Email: brian@csp-inc.org

Present address

Brian Folt, Conservation Science Partners, Truckee, California, USA.

Funding information

U.S. Bureau of Land Management, Grant/Award Numbers: 4500065781, L19PG00052; U.S. Geological Survey

Handling Editor: Matthew A. Mumma

Abstract

Feral horse (*Equus caballus*) population management is a challenging problem around the world because populations often exhibit density-independent growth, can exert negative ecological effects on ecosystems, and require great cost to be managed. However, strong value-based connections between people and horses cause contention around management decisions. To help make informed decisions, natural resource managers might benefit from more detailed understanding of how horse management alternatives, including combinations of removals and fertility control methods, could achieve objectives of sustainable, multiple-use ecosystems while minimizing overall horse handling and fiscal costs. Here, we describe a modeling tool that simulates horse management alternatives and estimates trade-offs in predicted metrics related to population size, animal handling, and direct costs of management. The model considers six management actions for populations (removals for adoption or long-term holding; fertility control treatment with three vaccines, intrauterine devices, and mare sterilization), used alone or in combination. We simulated 19 alternative management scenarios at 2-, 3-, and 4-year management return intervals and identified efficiency frontiers among alternatives for trade-offs between predicted population size and six management metrics. Our analysis identified multiple alternatives that could maintain populations within target population size ranges, but some alternatives (e.g., removal and mare sterilization, removal and GonaCon treatment) performed better at minimizing overall animal handling requirements and management costs. Cost savings increased under alternatives with more effective, longer lasting fertility control techniques over longer management intervals compared with alternatives with less-effective, shorter lasting fertility control techniques. We built a user-friendly website application, *PopEquus*, that decision makers and interested individuals can use to simulate management alternatives and evaluate trade-offs among management and cost metrics. Our results and website

This is an open access article under the terms of the [Creative Commons Attribution](https://creativecommons.org/licenses/by/4.0/) License, which permits use, distribution and reproduction in any medium, provided the original work is properly cited.

© 2023 The Authors. *Ecosphere* published by Wiley Periodicals LLC on behalf of The Ecological Society of America. This article has been contributed to by U.S. Government employees and their work is in the public domain in the USA.

application provide quantitative trade-off tools for horse population management decisions and can help support value-based management decisions for wild or feral horse populations and ecosystems at local and regional scales around the world.

KEYWORDS

decision analysis, *Equus caballus*, fertility control, population model, trade-offs, wildlife management

INTRODUCTION

An atypical problem in wildlife management occurs when the population size of a species, N , is managed to be at a target population size, N_t , that is below where density-dependent regulatory mechanisms limit population growth. Populations experiencing density-independent growth lack significant mechanisms of population regulation (e.g., food limitation and predation); high demographic vital rates (survival and reproduction) cause population dynamics with strong, positive population growth (Lotka, 1907) that can cause N to quickly exceed N_t through time. The management target N_t can be achieved again by reducing N ; however, the population will require repeated, persistent management to achieve N_t on average into the future (Garrott, 2018). If such populations are not managed persistently, populations can become large, have negative ecological effects on ecosystems (Côté et al., 2004), become an increasingly unwieldy and costly management problem (Garrott & Oli, 2013), and potentially exhaust limited budgets for natural resource management (Runge, 2020). Regardless of management frequency, such populations will always grow to exceed management targets unless population vital rates are adjusted through management, such as through wildlife fertility control (Kirkpatrick & Turner, 1985).

Feral horse (*Equus caballus*) population management exemplifies the challenge of managing a species with strong positive population growth (National Research Council, 2013). Originally native to the Eurasian steppe (Olsen, 2016), *E. caballus* is a domesticated species that has been introduced by humans to non-native areas on all continents except Antarctica (Schoenecker et al., 2021). Released horses have created feral populations (Boyce et al., 2021; The Wildlife Society, 2020) that grow rapidly due to high reproductive rates (Ransom et al., 2016) because of a history of domestication (Price, 1984); reproductive rates remain high even when population densities are relatively high (Grange et al., 2009). Horse populations may also outcompete native species for limited resources (Gooch et al., 2017; Hall et al., 2018) and exert strong, negative ecological effects in arid

ecosystems (Beever et al., 2018; Davies & Boyd, 2019; Eldridge et al., 2020; Rubin et al., 2021), particularly when horse populations become excessively large (Coates et al., 2021). Given the size and plurality of negative effects caused by horses, a typical goal in the field of conservation biology could be to reduce horse populations through management so that negative ecological effects would be reduced (Simberloff et al., 2005). Such reductions are common for horse populations in the United States, for example, but may facilitate population growth by reducing populations below where they are affected by food limitation and density dependence (National Research Council, 2013). The management of horses is further complicated by the fact that horses are charismatic and often beloved by human populations (Chamberlin, 2006; Nimmo & Miller, 2007; Scasta, 2019) and are viewed as icons of national identity (Dawson & Hone, 2012) and pioneer spirit (U.S. Congress, 1971), and some countries (e.g., United States) have legal protection for certain designated free-roaming horse populations (e.g., 'Public Law 95-514'). For these reasons, human populations often seek to maintain the persistence of horse populations at densities beneath where they might experience density-dependent effects, so that horse populations have abundant resources to permit horse health, ecosystems are healthy, and landscapes can accommodate other multiple uses (Garrott, 2018). However, this goal is challenged by high risks of horse populations growing fast (National Research Council, 2013), exerting negative ecological effects, and requiring great cost to be managed (Garrott & Oli, 2013).

Horse population management is often contentious (de Steiguer, 2011; Nimmo & Miller, 2007; Symanski, 1996; Wagman & McCurdy, 2011). Central to this contention lies a multiple-objective decision problem (Hemming et al., 2022) with competing objectives of facilitating free-roaming horse populations due to strong emotional connections that humans have toward horses (Nimmo et al., 2007; Scasta et al., 2018) while also managing horse populations to promote ecosystem health and allow other multiple uses on the landscape.

Decision makers might benefit from understanding trade-offs between competing objectives that emerge among different alternatives (Converse, 2020; Hemming et al., 2022; Keeney & Raiffa, 1993). There are many alternative management actions that might be used to control horse populations (National Research Council, 2013), including gathering and removing animals (Bartholow, 2007), immunocontraceptive vaccines (e.g., GonaCon-Equine, ZonaStat-H; Baker et al., 2018; Kirkpatrick et al., 1992; Turner et al., 2007), intrauterine devices (IUDs) (Gradil et al., 2021; Holyoak et al., 2021), sterilization (e.g., colpotomy; Prado & Schumacher, 2017), and additional compound alternatives involving two or more management actions (Danvir, 2018; Garrott, 2018). Management alternatives can also be limited by legal constraints. In the United States, for example, some feral horses whose ancestors lived in 1971 on lands in 10 western states administered by the Bureau of Land Management (BLM) and the U.S. Forest Service (USFS) are protected by federal law as “wild horses” (U.S. Congress, 1971), and the US Congress forbids any federal agency from using or planning for the use of lethal population control. Legal and culturally acceptable management actions vary in their effectiveness to control horse population size and minimize fiscal cost. With so many management actions available, varying population and cost efficacy of management actions, and myriad ways to structure management, wildlife managers seeking to make informed decisions could benefit from an analytical tool that makes predictions and reveals trade-offs among competing objectives that arise across different alternatives.

Matrix population models are useful tools that can describe how age- or stage-structured populations function (Caswell, 2001), predict how populations might change in response to external influences (Morris & Doak, 2002), and therefore provide clarity about the consequences of management alternatives and trade-offs among them. Management of wild horses by the BLM has been partly informed by *WinEquus* (Jenkins, 2002), a software program that used an age-based population model for horses and estimates of initial population structure, survival rates, and reproductive rates to stochastically project populations and simulate how two management actions (removals and fertility reduction treatment) influence population size. *WinEquus* was useful because it allowed users to explore how removals and fertility reduction treatments of varying effectiveness could influence horse population size, and it was mainly used to project whether or not proposed levels of ZonaStat-H treatment would cause a population to decline precipitously (Bureau of Land Management, 2010). However, fertility control methods with different applications from vaccines have become available in recent years, and *WinEquus* was limited in its

ability to simulate more than one management action at a time and did not account for financial cost. Thus, we developed a predictive model for horse populations that considers multiple management alternatives, accounts for important metrics (e.g., population size and cost), and can accommodate site-specific variation in demography or management limitations (Garrott, 1991).

Here, we present a predictive modeling tool for horse population management that estimates the consequences of six management actions (removals, three fertility reduction vaccines [PZP-22, ZonaStat-H, and GonaCon-Equine], IUDs, and mare sterilization), used alone or paired with another management action, on horse population size, management cost, and metrics related to management. We built functions that simulated 19 alternatives for horse population management: six scenarios of single management alternatives (i.e., elemental alternatives), nine compound alternatives with two management actions (e.g., removals + fertility treatment), three compound alternatives with three management actions, and a null-model scenario of no management. We used our simulation code to build an interactive website application, *PopEquus*, which hosts the predictive model and allows managers, decision makers, and other interested individuals to simulate management alternatives, compare outcomes among alternatives, and understand trade-offs in horse population management.

MATERIALS AND METHODS

Study system

The BLM and USFS are tasked with managing federally protected wild horse populations so that population size does not fall beneath or exceed predetermined target population size ranges, which are called appropriate management levels (AMLs; National Research Council, 2013). Target population size ranges are designated by land managers to promote sustainable, multiple-use federal lands with the goal of maintaining a “thriving natural ecological balance” among horses, livestock, wildlife, and vegetation that protects rangelands from deterioration and yields sufficient food and water to permit high welfare of horses (National Research Council, 2013; U.S. Congress, 1971).

Federal management agencies in the United States monitor horse population size using aerial survey methods on a regular basis through time (Griffin et al., 2020; Lubow & Ransom, 2009, 2016). When horse populations exceed target population size ranges on federal lands, management agencies have sought to reduce population size by removing horses from the landscape (National Research Council, 2013). Removals involve rounding up

horses during a “gather” and removing individuals to decrease population size to be within AML. Removed horses are taken to a holding facility and entered into a federal adoption program, where private citizens can adopt horses for personal ownership (Adopt-A-Horse Program; Smith, 2010). The challenge is that gathers and animal care in captivity are expensive, demand for horse adoption has declined in recent decades, and many horses are never adopted, which leads to a growing captive population at holding facilities and increased costs associated with removals as a management action (ca. \$50 million per year; Garrott, 2018; Garrott & Oli, 2013). Perhaps most importantly, removals alone fail to change any underlying demographic process to prevent the population from quickly returning to the overpopulated state. While removals can reduce population sizes to be within target population size ranges in the short term, populations quickly grow to exceed management targets without concomitant reductions in reproduction or survival, while incurring significant costs in holding and requiring necessary future management.

For these reasons, managers have sought alternatives that reduce population vital rates (Bechert et al., 2022). A demographic sensitivity analysis found that horse population dynamics are more sensitive to adult survival than juvenile survival or reproduction (Garrott, 1991), but euthanizing healthy wild horses is illegal. Therefore, management efforts have focused on reducing reproductive rates of populations (hereafter, fertility treatment). In particular, immunocontraceptive vaccines (e.g., PZP vaccines; hereafter, vaccines) have been developed that, when applied to female horses, reduce reproductive rates in subsequent years (Kane, 2018). Vaccines are viewed as a favorable management alternative by some because vaccine application does not necessarily require gathering horses (e.g., remote delivery of vaccine by darting can be used, although darting can be logistically difficult and is often viewed as practically impossible) or moving individuals to holding facilities, which are both expensive procedures. However, vaccines are <100% effective at reducing pregnancy, and currently available vaccines require re-treatment to remain effective over time. Therefore, vaccine treatment alone cannot reduce reproductive rates sufficiently to allow natural mortality to exceed recruitment and decrease population size to be within target population size ranges within a desirable time period. More recently, IUDs have been developed as another fertility control method. IUDs can be implanted in nonpregnant females and are 100% effective at preventing pregnancy so long as they remain in the uterus (Gradil et al., 2021; Holyoak et al., 2021). However, most types of IUDs tested over longer time periods (>1 year) are not retained perfectly, and preliminary studies suggest that annual

retention rates are between 80% and 90% (Daels & Hughes, 1995; Gradil et al., 2019; Holyoak et al., 2021). IUD use is further limited because treatment can only be given to nonpregnant females, which often comprise a small subset of the female horse population at any time.

Perhaps the most effective form of fertility treatment would be sterilization of mares (National Research Council, 2013) because mare sterilization results in long-lasting 100% effective fertility control of treated individuals with no re-treatment required. Multiple surgical methods have been used successfully for domestic horses (Bigolin et al., 2009; Edwards et al., 2021; Hendrickson, 2012; Prado & Schumacher, 2017; Rodgerson & Loesch, 2011). Mare sterilization applied to free-roaming horse populations might be functionally similar to “trap-neuter-return” programs used to manage feral cat and dog populations throughout much of the United States (Levy et al., 2003; Longcore et al., 2009).

Surgical castration of males (i.e., gelding or vasectomy; King et al., 2022; Scully et al., 2015) is commonly used for domestic horses and is another potential population management tool to decrease reproduction by reducing fertilization rates. One study reported slight decreases in female fertility in a feral horse herd that included some sterile males (Collins & Kasbohm, 2017). Another study observed decreased reproductive rates of females for one year after castrating 42% of males in a horse population, but reproduction returned to pretreatment levels in subsequent years (King et al., 2022). Because females can experience 6–10 reproductive cycles per year and encounter multiple males during that time, researchers have concluded that male sterilization is unlikely to be an effective tool to manage horse reproduction (unless an extremely large portion [>90%] of a population is gelded; Garrott & Siniff, 1992; King et al., 2022). For this reason, we did not include gelding as a management alternative in our analysis.

Management actions

We worked with natural resource managers to identify management actions available and of interest for horse management in the present and/or near future and to co-produce a model to simulate those management actions. We identified six management actions of interest: removals, three fertility reduction vaccines (GonaCon-Equine, PZP-22, and ZonaStat-H), IUDs, and mare sterilization.

Removals

Removals are a commonly used management strategy to directly decrease the number of individuals in a

population to AML (National Research Council, 2013). To do a removal, a “gather” collects horses from a population (either by means of bait trapping or using helicopters to herd individuals into corral traps; Scasta, 2020), and individuals are removed from the landscape to meet a target population size. The sex ratio or age structure of individuals being removed can be manipulated strategically to restructure the population in ways to help might minimize future population growth (e.g., removing more females than males, when possible; Bartholow, 2007; National Research Council, 2013). Removed horses are taken to a short-term holding facility, where they are vaccinated against communicable diseases, dewormed, freeze-branded, and microchipped and are held until they are offered to qualified citizens for adoption. While at the holding facility, females and males are kept in separate pens to prevent conflict among horses and new pregnancies. Unadopted horses are eventually taken to off-range pastures where they live out their lives.

Fertility control vaccines

Three forms of fertility control vaccine have recently been used to reduce the fertility of free-roaming horse populations in the United States. GonaCon-Equine (hereafter, GonaCon) is a vaccine that reduces horse fertility by manipulating a critical hormone related to reproduction, the gonadotropin-releasing hormone (Kane, 2018). GonaCon can be injected by hand or by dart and has perhaps the greatest potential for utility among the fertility-reducing vaccines, as it can be upwards of 90% effective at reducing fertility for several years after a booster dose is given (Baker et al., 2018). Porcine zona pellucida (PZP) vaccines are vaccines with a glycoprotein antigen from domestic pig (*Sus scrofa*) ovaries that, when given to a female horse, stimulates the immune system to produce antibodies to zona pellucida proteins on eggs, thereby blocking fertilization and decreasing ovary function over time (Kane, 2018; Kirkpatrick et al., 1992). The most commonly used form of PZP is ZonaStat-H (hereafter, ZonaStat), a liquid vaccine that can be injected by hand or by dart. ZonaStat is 80%–90% effective at preventing pregnancy for one year when a booster shot is given 30 days after initial treatment and 1–2 months before the breeding season (National Research Council, 2013). However, ZonaStat utility is limited because it must be administered annually to maintain effectiveness, although mares treated five or more times may have longer lasting effects (Nuñez et al., 2017). An alternative form of PZP is PZP-22, a pellet formulation of PZP with an extended release period and longer effectiveness (National Research Council, 2013). Field

trials have found varying effectiveness of PZP-22 (Kane, 2018; Turner et al., 2007); however, recent results indicate that PZP-22 applied with booster treatments may cause a 15%–40% reproductive rate of treated horses over a three-year period, relative to ca. 70% reproduction among untreated mares (Rutberg et al., 2017). It is important to note that fertility control treatments may lead to increased survival and longevity of treated females (Kirkpatrick & Turner, 2007), likely because vaccine treatment eliminated energetic demands and mortality risks associated with pregnancy, birth, and lactation.

Intrauterine devices

Safe and flexible IUDs were first designed for and implemented in horses in the 1990s; an O-ring design made with silastic elastomer polymer was found to be effective at preventing pregnancy (Daels & Hughes, 1995), but further investigation found O-ring devices to often be expelled shortly after insertion (Holyoak et al., 2021). Recent development of a Y-shaped silastic IUD has fairly high retention within females (ca. 86.6% retention per year) and is 100% effective at preventing pregnancy when intact (Holyoak et al., 2021). Mares must not be pregnant to receive an IUD.

Mare sterilization

Mare sterilization would be the most effective form of fertility treatment because sterilization requires only a single treatment and is 100% effective at preventing future pregnancy (National Research Council, 2013). Even though the BLM has not yet used mare sterilization as a management action for wild horses, we included mare sterilization among our set of alternative management actions and scenarios because some form of mare sterilization could possibly be used in the future.

Model structure

We simulated how horse population size is influenced by different management actions using matrix population models (Caswell, 2001). We built matrices of demographic vital rates (survival, reproduction) and age-structured abundance in populations and used matrix multiplication to project populations forward in time. We built an age-based, two-sex, postbreeding census Leslie population model (Leslie, 1945) for horse populations, wherein we conceptualized horse demography as having

21 age classes for each sex: one age class for each year of age from 0 (foals) to 19 years old, and a final stage with all individuals ≥ 20 years old (Figure 1). During a given time-step, individuals in each age class had a probability of surviving and transitioning to the next age class, until they reached age 20; all individuals ≥ 20 years old were modeled as a single-stage class with a probability of surviving and staying within that stage. Females of age ≥ 2 years old had a probability of reproducing (foaling) and recruiting individuals into the foal age class. Individuals that did not survive and transition during a time-step were assumed to have died.

Because demographic rates of populations vary in space and time, we used studies of wild horse populations in western North American ecosystems to build 10 matrices describing different plausible demographic conditions for horses. Three studies came from the Pryor Mountains in Montana during different time periods (Garrott & Taylor, 1990; Jenkins, 2002; Roelle et al., 2010), and two studies were from Nevada (Jenkins, 2002); these multiyear studies estimated demographic rates using mark-resight data. We built demographic matrices from these studies that yielded mean population rates of change (λ) ranging from 1.066 to 1.178 and one matrix

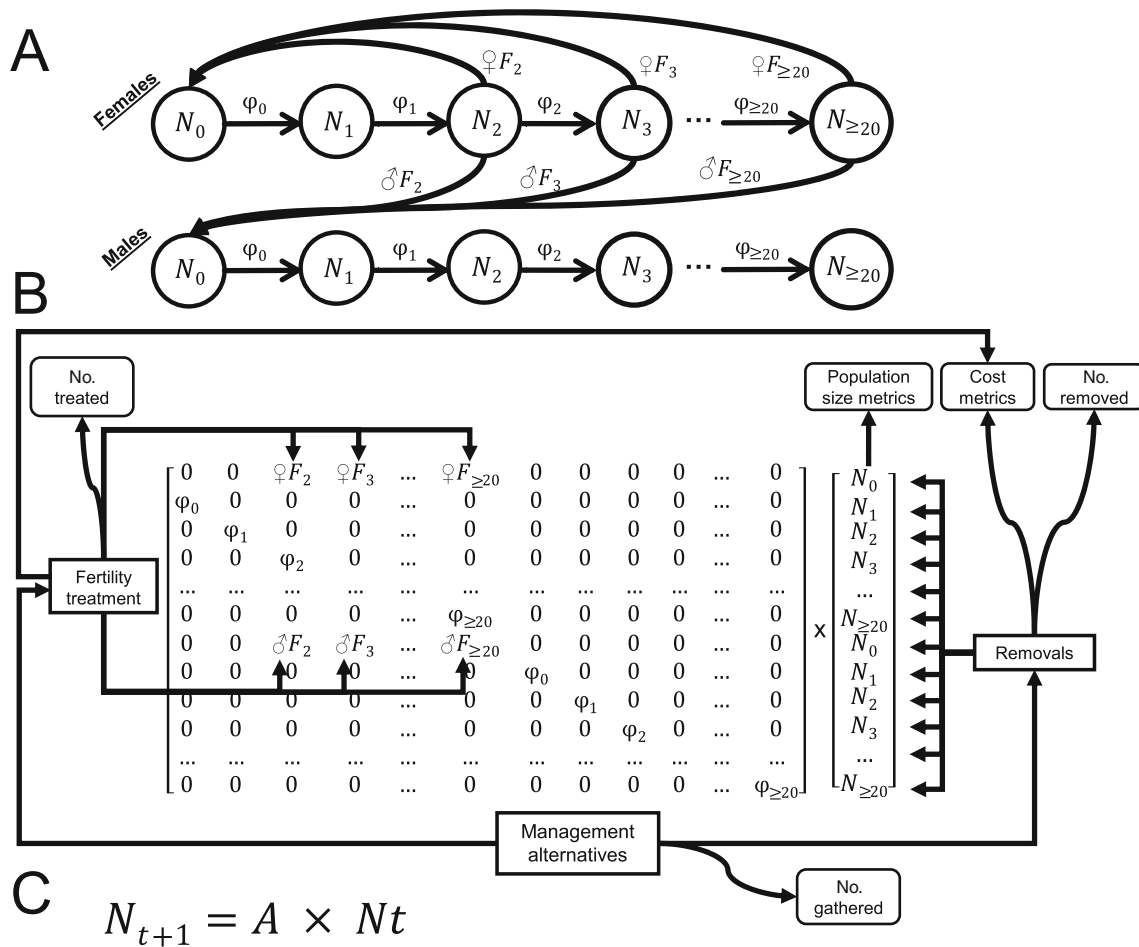

FIGURE 1 An age-based, two-sex, population projection model for free-roaming horses (*Equus caballus*). (A) A conceptual diagram illustrating how abundance (N), survival (φ), and fecundity (F) vary by age stages (subscripts: 0, 1, 2, ..., ≥ 20 years old); circles denote age-class abundance, arrows indicate survival and reproductive rates, and “...” indicates abundance and demographic rates for ages 3–19. (B) An illustration of how parameters from the conceptual model (N , φ , F) were articulated with a matrix of demographic rates (left) and a vector of initial population size (right) for population projection. Dotted lines (...) indicate when rows and columns were collapsed for illustrative purposes. The top 21 rows of the vector and matrix describe parameters for females and the bottom 21 rows are for males. For fecundity terms, the proportion of offspring that were female and male were indicated by the symbols ♀ and ♂, respectively. Stochastically drawn demographic rates at time t were multiplied by the vector of population size to project the population size vector forward to time $t + 1$. Rectangles are management alternatives; arrows are effects of management alternatives on demographic rates, population size, and management metrics (round-cornered rectangles). No. gathered = number gathered; no. removed = number removed; no. treated = number treated. (C) Population size at time $t + 1$ (N_{t+1}) is a product of the demographic rate matrix (A) and abundance at time t (N_t).

with $\lambda < 1$ that described high-mortality demographic conditions that can occur during uncommon extreme weather events (Table 1). However, a global review of horse population dynamics suggested that λ can vary widely (range: 0.84–1.39; Ransom et al., 2016). Given the great range of potential λ values, we built four additional matrices that approximated conditions toward the upper range of potential λ values, which could yield λ of 1.14–1.32. In total, we built 10 demographic matrices that represented variable demographic conditions experienced by horse populations in space and time.

To understand the consequences of management alternatives on horse population size, we modeled a population of 500 individuals (including foals in a postbreeding census) that occurred on a hypothetical management area of federally owned land with a target population size range of 200–300 horses. We chose to model an overpopulated context, because most horse populations on BLM-managed lands currently exceed AML (e.g., 79% exceeded maximum sizes in 2022; Bureau of Land Management, 2020). To specify initial population structure for simulations, we estimated the average percentage of a population in each age class using population structure data from a study at Garfield Flat, Nevada, where no recent gathers or management had occurred (data from Jenkins, 2002). We multiplied the population estimate by the population structure vector to specify initial population structure vector for projections.

While horse populations have occasionally been observed to decline in size between consecutive years, no study has documented negative population rate of change

of horses consistent with declines over long-term, multiyear periods (i.e., mean $\lambda < 1.00$). For this reason, our model assumed a baseline of increasing λ over multiyear timescales with a minimum and maximum mean λ of 1.00 and 1.32. For each 0.01 value within and including $\lambda = 1.00$ –1.32, we created a vector of probability values associated with the 10 demographic matrices, where each matrix was assigned a weighted probability value and the sum of the product of each matrices' λ value and its weighted probability generated a mean λ for each decimal value. For any given user-specified λ between 1.00 and 1.32, we used the 10 matrices and their weighted probability values to project the population for 10 years using two functions: (1) a deterministic function without random variation, and (2) a stochastic projection function that simulated random temporal (i.e., environmental) and demographic variation. During deterministic projections, we projected the population using matrix multiplication of each of the 10 demographic matrices by the population structure vector and then used the probability weights for each matrix to calculate a single, weighted-average outcome from among the 10 projections. During stochastic projections, we performed 100 replicate projections for each scenario. In each year within each replicate, we randomly drew one of the 10 demographic matrices using the matrix probability weights, which prescribed the likelihood of a population experiencing each of the demographic matrices in a given year (Table 1). We then projected the population one time-step in the future (year) by multiplying the stochastically drawn demographic matrix by the population

TABLE 1 Studies of free-roaming horses (*Equus caballus*) used to build age-based Leslie matrix models describing horse demographics in western North America.

No.	State	Site	Year	λ	Probability	Reference
1	Montana	Pryor Mountains	1976–1986	1.148	0.08	Garrott and Taylor (1990)
2	Montana	Pryor Mountains	1977	0.533 ^a	0.00	Garrott and Taylor (1990)
3	Montana	Pryor Mountains	1996–2000	1.089	0.01	Jenkins (2002)
4	Montana	Pryor Mountains	1993–2007	1.066	0.00	Roelle et al. (2010)
5	Nevada	Garfield Flat	1993–1999	1.178	0.42	Jenkins (2002)
6	Nevada	Granite Range	1979–1983	1.138	0.06	Berger (1986)
7				1.196	0.27	Ransom et al. (2016)
8				1.231	0.10	Ransom et al. (2016)
9				1.143	0.06	Ransom et al. (2016)
10				1.317	0.00	Ransom et al. (2016)

Note: Each matrix yielded a distinct deterministic population rate of change that spanned a range of possible λ values for horses (Ransom et al., 2016). During each year of stochastic population projections, one matrix was randomly drawn, given the probability p , to yield an overall mean λ of 1.18 among years. Other matrix probability vectors can be used to simulate additional mean values for λ that vary from 1.00 to 1.32 using the *PopEquus* simulation tool (Folt, Ekernas, et al., 2023).

^aLow survival from an extreme winter; lower limit of population growth.

structure vector using the function “multiresultm()” from the package “popbio” (Stubben & Milligan, 2007), which uses a random binomial function to stochastically generate the number of births during each time-step. When simulating different scenarios, we held temporal stochasticity constant by drawing the same order of demographic matrices among years within and among replicates during stochastic projections. During stochastic projections, we assumed a population persistence threshold where if the population decreased beneath 30 individuals, the population was at elevated risk of becoming locally extirpated due to demographic, environmental, or genetic stochasticity; we measured the percentage of replicates that resulted in populations above the persistence threshold.

Management alternatives

Based on the six management actions described above, we constructed 19 alternative scenarios for horse management: six alternatives each with a single management action, nine compound alternatives involving two management actions, three compound alternatives involving three management actions, and a null-model scenario of no management for comparative purposes (Table 2). We built a predictive function for each alternative that simulates how the management action(s) influences horse population size and metrics related to animal handling and cost objectives. We then performed a scenario analysis (described below) to estimate the consequences of alternatives where we simulated each alternative under comparable conditions.

Simulation conditions

We simulated each management scenario under similar population and management conditions and measured the consequences of management alternatives on important value-based metrics related to population management (described below). We assumed a population size of 500 individuals from a postbreeding census (including foals), a mean λ of 1.18 (Ransom et al., 2016), and a manager-specified target population size range of 200–300 individuals. We simulated management scenarios by projecting the population 10 years into the future under scenarios involving gathers and management every three years starting in the first year (i.e., years 1, 4, 7, and 10). During scenarios with two or three management actions, management actions were performed on the same years if population conditions were suitable for each action. We assumed that gathers would result in the collection of 75% of the true total population size for

management. We estimated per-horse cost of gathers as varying depending on the number of horses gathered using cost approximations from the BLM (Paul Griffin, personal communication), with larger gathers having lower costs per horse (e.g., 1000 horses cost \$668 per horse) than smaller gathers (e.g., 100 horses cost \$1074 per horse).

Removals

We simulated removals where, during designated removal years when the population size exceeded the maximum of the target population size range (300 individuals), managers collect a large segment of a population during a gather, and individuals are selectively removed to reduce the population size to a target population size of the minimum of the target population size range (200 individuals). We assumed that (1) managers would selectively remove more females than males from among the gathered horses, when possible, so that individuals released back to the population have a male-biased structure (6 males:4 females; Bartholow, 2007; National Research Council, 2013); (2) the maximum number of individuals that can be removed from a population and taken to a holding facility in a single year is 1500; (3) removed individuals are taken to a short-term holding facility where they become a captive population that is available for public adoption for one year; and (4) any horses that are not adopted after one year in captivity are taken to a long-term holding facility to live out their lives. We projected the population in holding for the rest of the 10-year projection interval and an additional 25 years, which approximates the maximum longevity of horses in captivity. While female and male horses are kept separate in holding facilities to prevent reproduction, some females are pregnant upon being removed and give birth during their first year in captivity. To project horse populations in holding facilities, we assumed that (1) female reproduction during the first year in captivity is a 25% reduction of the birth rate experienced by females in the wild population the year the horses were removed; (2) 69% of removed horses and any offspring produced during the year in short-term holding are removed from the captive population as a result of adoption, sale with limitation, or transfer to government agencies (this is an average of 2019–2021; <https://www.blm.gov/programs/wild-horse-and-burro/about-the-program/program-data>); (3) females do not reproduce in long-term holding facilities; and (4) all captive individuals experience an annual survival rate of 0.95 (Government Accountability Office, 2008). Costs associated with removals as a management strategy include short-term

TABLE 2 Simulated outcome metrics (mean [95% CIs]) for free-roaming horse (*Equus caballus*) populations under 19 management alternatives.

Management alternatives	Alternative no.	Population size		No. horses		No. horse treatments	Cost (USD; millions)		
		Final	Mean	Gathered	Removed		On-range	Off-range	Total
No management	1	2537 (2206–2898)	1253 (505–2632)	0 (0–0)	0 (0–0)	0 (0–0)	0 (0–0)	0 (0–0)	0 (0–0)
Removals	2	271 (208–341)	289 (194–505)	972 (803–1160)	530 (445–617)	0 (0–0)	0.84 (0.69–1)	3.89 (3.13–4.52)	4.73 (3.81–5.51)
GonaCon	3	924 (811–1048)	705 (505–951)	2634 (2463–2849)	0 (0–0)	960 (885–1025)	2.2 (2.07–2.34)	0 (0–0)	2.2 (2.07–2.34)
PZP-22	4	1710 (1461–1974)	990 (505–1788)	3599 (3195–4026)	0 (0–0)	1223 (1130–1399)	2.94 (2.68–3.25)	0 (0–0)	2.94 (2.68–3.25)
ZonaStat-H	5	1794 (1610–1960)	984 (505–1855)	3583 (3282–3829)	0 (0–0)	1178 (1098–1247)	2.78 (2.57–2.95)	0 (0–0)	2.78 (2.57–2.95)
IUDs	6	1795 (1533–2100)	1013 (505–1866)	3693 (3307–4071)	0 (0–0)	484 (412–605)	2.8 (2.55–3.02)	0 (0–0)	2.8 (2.55–3.02)
Mare sterilization	7	692 (615–767)	638 (505–745)	2392 (2236–2535)	0 (0–0)	384 (350–413)	2.02 (1.92–2.1)	0 (0–0)	2.02 (1.92–2.1)
Removals and GonaCon	8	238 (192–327)	279 (186–505)	1283 (1202–1355)	401 (312–454)	237 (185–272)	1.19 (1.14–1.25)	2.97 (2.31–3.43)	4.16 (3.46–4.67)
Removals and PZP-22	9	278 (196–340)	290 (192–505)	1340 (1271–1426)	478 (417–569)	207 (162–242)	1.24 (1.19–1.31)	3.46 (3.07–4.03)	4.71 (4.27–5.33)
Removals and ZonaStat-H	10	291 (234–356)	292 (193–505)	1354 (1270–1443)	493 (415–578)	209 (170–252)	1.23 (1.17–1.3)	3.59 (3.04–4.21)	4.82 (4.21–5.43)
Removals and IUDs	11	268 (203–344)	284 (192–505)	1326 (1267–1428)	477 (423–572)	62 (39–86)	1.2 (1.15–1.27)	3.52 (3.04–4.18)	4.72 (4.23–5.42)
Removals and mare sterilization	12	258 (180–310)	277 (189–505)	1254 (1171–1342)	342 (312–441)	127 (87–151)	1.17 (1.11–1.23)	2.56 (2.2–3.26)	3.73 (3.36–4.49)
IUDs and GonaCon	13	1038 (894–1198)	746 (505–1087)	2770 (2537–3008)	0 (0–0)	789 (711–871)	2.23 (2.08–2.39)	0 (0–0)	2.23 (2.08–2.39)
IUDs and PZP-22	14	1780 (1341–2317)	984 (505–2013)	3498 (2980–4074)	0 (0–0)	1055 (832–1302)	2.78 (2.44–3.17)	0 (0–0)	2.78 (2.44–3.17)
IUDs and ZonaStat-H	15	1500 (1242–1719)	892 (505–1580)	3271 (2869–3522)	0 (0–0)	939 (823–1035)	2.51 (2.29–2.67)	0 (0–0)	2.51 (2.29–2.67)
IUDs and mare sterilization	16	685 (597–794)	604 (505–722)	2296 (2131–2473)	0 (0–0)	413 (371–449)	1.94 (1.83–2.05)	0 (0–0)	1.94 (1.83–2.05)
Removals with IUDs and GonaCon	17	224 (182–323)	279 (186–505)	1299 (1208–1371)	428 (312–488)	177 (137–212)	1.18 (1.1–1.24)	3.17 (2.26–3.62)	4.35 (3.4–4.86)
Removals with IUDs and PZP-22	18	275 (193–369)	295 (193–505)	1355 (1279–1489)	513 (422–622)	171 (133–229)	1.25 (1.19–1.36)	3.78 (3.15–4.47)	5.03 (4.35–5.79)
Removals with IUDs and ZonaStat-H	19	261 (217–329)	283 (192–505)	1319 (1254–1412)	464 (420–526)	172 (149–199)	1.19 (1.14–1.26)	3.39 (3.06–3.93)	4.58 (4.22–5.17)

Note: Populations were simulated using a predictive function for each alternative assuming a starting population size of 500 individuals, appropriate management levels of 200–300 individuals, 10-year projection interval with an average annual population rate of change of 1.18, and a three-year return interval between animal handling events (gathers, removals, fertility control treatments). Management costs were calculated over 10 years on public land (on-range), 35 years when horses were removed and taken to holding facilities off range (off-range), and 35 years for the total cost. Abbreviation: IUDs, intrauterine devices.

holding of animals in captivity (\$7.60 per horse daily; Paul Griffin, personal communication), long-term holding of animals in captivity (\$2.02 per horse daily; Paul Griffin,

personal communication), and an average net administration cost to adopt out a horse (\$1700; Paul Griffin, personal communication).

Fertility control vaccines

We modeled fertility control vaccination as a management action where, during vaccine treatment years, gathers are performed to collect horses and administer vaccine to all females ≥ 1 year old that are to be released back onto the range. Vaccine-treated individuals were then subject to different reproductive and survival rates, depending on how many vaccine doses they received and the number of years since the last dose. Because fertility control using vaccine increases survival and longevity of females (Kirkpatrick & Turner, 2007), we increased survival rates of all fertility-control-treated females by multiplying the age-specific survival rate of untreated females by 1.02 to accommodate for likely increases in survival due to reduced future pregnancy (*sensu* Kirkpatrick & Turner, 2007).

We modeled the effects of GonaCon treatment on reproductive rates using results from published field trials in Theodore Roosevelt National Park, North Dakota, USA (Baker et al., 2018). GonaCon has relatively weak effects when individuals are only given one dose (e.g., ca. 37% and 29% reductions in fertility after one and two years, respectively), but substantially stronger effects when individuals are treated with a booster shot (i.e., a second shot; 100%, 85%, and 50% reductions in fertility during 1, 2–4, and 5–7 years after booster shot; Baker et al., 2018; Paul Griffin, personal communication). We assumed all GonaCon-treated individuals would be held for 30 days to receive a booster. Costs associated with GonaCon treatment included gathering horses, giving primer and booster shots (\$50 each) to eligible females, and holding treated females for a booster (\$7.60 per day [Paul Griffin, personal communication] for 30 days).

We modeled the efficacy of PZP-22 using results from Rutberg et al. (2017). Because PZP-22 batches can vary in effectiveness, we modeled a stochastic effect where batch effectiveness was a randomly drawn value between the minimum and maximum effectiveness of receiving one dose, two doses, or three doses observed through time in field studies. We assumed that minimum and maximum percent reductions in fertility from PZP-22 treatments were 33%–72% one year after a primer dose and 20%–40% two years after receiving a primer; 68%–85% one, 70%–75% two, and 60%–72% three years after receiving a booster; and 78%–95% one, 80%–85% two, and 70%–82% three years after receiving an additional booster. Effectiveness rates for the hypothetical third dose of PZP are suppositions based on expert elicitation (Paul Griffin, Bureau of Land Management). A single treatment of PZP-22 includes two injections: intramuscular injection of three polymer pellets that are intended to degrade over different time intervals and also injection of one dose of

ZonaStat-H (Kane, 2018). Costs associated with PZP-22 treatment included gathering horses, giving a dose of the PZP pellets that confer longer immunogenic effects (\$400) and a dose of ZonaStat-H vaccine (\$30) to eligible females, and holding treated females for 7 days before they are returned to the range (\$7.60 per day for 7 days; Paul Griffin, personal communication). Additional booster doses involved re-treatment with ZonaStat-H.

We modeled the effects of ZonaStat-H treatment on reproductive rates using results from published field trials (Kirkpatrick & Turner, 2008; Nuñez et al., 2017; Turner et al., 1997). We assumed that ZonaStat-H treatment would involve all treated females being held in short-term captivity to receive a booster shot 30 days after they received a primer dose to increase effectiveness (i.e., two doses). We modeled ZonaStat-H effects as 95% and 19% reductions on reproduction one and two years, respectively, after receiving two doses (Kirkpatrick & Turner, 2008; Turner et al., 1997); 95% and 19% reductions one and two years, respectively, after receiving a third dose (Kirkpatrick & Turner, 2008; Turner et al., 1997); 95%, 72%, 58%, and 30% reductions one, two, three, and four years, respectively, after receiving a fourth dose (Nuñez et al., 2017); and a persistent 95% reduction after receiving a fifth dose (Nuñez et al., 2017). Costs associated with ZonaStat-H treatment included gathering horses, giving primer and booster shots (\$30 each) to eligible females, and holding treated females for a booster (\$7.60 per day for 30 days).

Intrauterine devices

Because our model assumes a postbreeding census with management occurring after the birthing season, management may occur when females are most likely to not be pregnant and therefore are available to receive an IUD. We modeled IUD treatment assuming that, during treatment years, populations are rounded up in a gather, gathered females are screened by a veterinarian for pregnancy using ultrasonography, and all nonpregnant females ≥ 1 year old are given an IUD and returned to the range. We estimated the proportion of nonpregnant females using one minus the fertility rate for each female age class specified by the randomly selected demographic matrix during each year of projections. Nonpregnant females implanted with an IUD implanted at the beginning of a year cannot become pregnant during the following year, and IUDs have an annual retention probability of 0.86 (extrapolated from Holyoak et al., 2021). Survival rates of IUD-treated females were increased, as with during vaccine treatment. Costs associated with IUD implantation included gathering horses,

using veterinary ultrasound to scan all females to determine pregnancy status (\$30 per female), materials (\$60 per device for each nonpregnant female), veterinarian costs (\$50 per device implanted), and holding costs associated with treatment (\$5 per day for 14 days per treated female).

Mare sterilization

We modeled mare sterilization assuming that during treatment years, populations are rounded up in a gather and all females ≥ 1 year old are sterilized. Because a portion of the gathered female population will be pregnant during a treatment year, we assumed that all pregnant females would carry out their current pregnancy in the immediate year, but that all females would be unable to reproduce in all future years. Survival rates of sterilized females were increased, as with during other fertility control treatments. We assumed costs associated with mare sterilization as gathering horses, performing the procedure (\$300 per individual), and holding costs associated with seven days of posttreatment monitoring (\$5 per day).

Functions for compound alternatives

We built nine functions that each simulated how two management actions (i.e., compound alternatives) can be used jointly to manage horse populations. Five functions used removals along with a fertility treatment (one of three different vaccines, IUDs, or mare sterilization). During treatment years with removals and fertility control, the functions simulated gathers and removals from the population first, and then fertility treatment of the remaining gathered females second. If fertility-treated individuals were present during a removal, untreated females would be preferentially selected for removal. Removals sought to reduce the population size to the target size, if possible, and fertility control treatment was applied to the remaining mares that would be released back to the range. We built four functions simulating how IUDs could be used jointly with another form of fertility treatment (GonaCon, PZP-22, ZonaStat, or mare sterilization). When treating IUDs with vaccine or mare sterilization, all nonpregnant females were implanted with IUDs first, and then the remaining pregnant females were treated with vaccine or sterilization.

We also built three functions that simulated how three management actions could be used jointly for management: “Removals with IUDs and GonaCon,” “Removals with IUDs and PZP-22,” and “Removals with IUDs and ZonaStat-H.” All three functions involved

managing with removals first (when the population met removal conditions) and then treating any remaining females with IUDs (nonpregnant females) or vaccine (pregnant females). A full list of the predictive functions is included in Table 2.

Metrics

Management alternatives trade-off in creating outcomes related to population size, the amount of animal handling performed, and fiscal costs (Folt et al., 2022). We quantified seven metrics during simulations and used them to evaluate the performance of alternatives: mean population size, number of horses gathered, number of horses removed, number of horses treated, cost (USD) of management in the field (on-range), cost (USD) in holding facilities (off-range), and total cost of management (sum of on-range and off-range costs). Mean population size can be viewed as an index of potential ecological impacts to ecosystem health and horse health. When management causes populations to be within target population size ranges, ecological effects of horses are small enough to permit high ecosystem health (i.e., healthy, multiuse landscapes) and horses have sufficient resources (i.e., food and water) to permit high horse health (Bureau of Land Management, 2010; National Environmental Policy Act, 1970). When horse populations exceed target ranges, horse overpopulation might have negative effects on ecosystem health (i.e., ecological costs). At even higher horse population sizes, there may be increased risk of negative density-dependent effects on horse welfare due to resource limitation. The number of horses gathered, removed, and treated are indices of the magnitude of animal handling; management alternatives that are effective in reducing population size and minimizing the amount of animal handling necessary may be preferred by some members of the public, who often prefer the level of horse handling to be minimized (Carlisle & Adams, 2022; Folt et al., 2022). Management costs on-range, off-range, and overall are indices of fiscal costs of management. So long as the primary management goals for natural resources are met (e.g., achieving a thriving natural ecological balance through AML), most stakeholders and decision makers would prefer to minimize management costs to save limited financial resources.

Estimating trade-offs

We first sought to understand trade-offs by simulating 19 alternatives (Table 2) under scenarios where

management with gathers, handling, and treatment was performed in the first year and every third year thereafter during a 10-year projection interval. We summarized outputs for each alternative with mean and 95% CI estimates for each metric.

Management with gathers, handling, and treatment performed at different frequencies might better achieve different objectives in horse management (Folt et al., 2022). To understand trade-offs among metrics predicted by management alternatives conducted at different frequencies, we simulated two additional scenarios for each alternative and compared outcomes from when management is performed every three years (scenario 1) to when management frequency is increased (every two years; scenario 2) or decreased (every four years; scenario 3) over a 10-year interval. For a given outcome of one metric, alternatives may vary substantially in the outcome of another objective, such that one alternative may outperform (i.e., dominate) others at minimizing metrics. We illustrated outcomes for each alternative scenario (55 total, including a “No management” scenario) using point graphs and identified Pareto efficiency frontiers (Keeney & Raiffa, 1993) describing the most efficient scenarios for minimizing individual metrics (e.g., cost) along variation of outcomes for predicted mean population size (Runge et al., 2020) among all alternatives. A Pareto efficiency frontier represents the best possible outcomes for the two metrics among the multiple management alternatives considered. Alternatives on the Pareto efficiency frontier are “Pareto optimal,” because it is not possible to identify another alternative that increases performance in one metric without decreasing performance in another metric (Lyons, 2020). We identified Pareto efficiency frontiers among all alternatives for between overall mean population size and six metrics: (1) number of horses gathered, (2) number of horses removed, (3) number of horses treated, (4) management cost in the field (on-range), (5) management cost in holding facilities (off-range), and (6) total management cost. Three of the alternatives that we simulated involved mare sterilization as a management action (Mare sterilization, Removal and mare sterilization, IUDs and mare sterilization; Table 2). However, there is some public resistance to certain surgical methods for mare sterilization of horses in field settings (Bechert et al., 2022). For this reason, we identified a second Pareto efficiency frontier that identified the most efficient scenarios for minimizing metrics among alternatives that did not involve mare sterilization.

The effectiveness of alternatives for minimizing metrics might also vary by the temporal scale of management, where the effectiveness of alternatives at minimizing metrics changes over longer time periods. To this end, we simulated four alternatives

(Removals; Removals and GonaCon; Removals, IUDs, and GonaCon; Removals and mare sterilization) with management every three years over a 20-year projection interval and compared results between the 10- and 20-year projection intervals to understand how the duration of management with gathers and treatment influences important metrics in horse management.

Code

We built all simulation functions and performed scenario analyses in the statistical program R (R Core Team, 2021) using the package “popbio” (Stubben & Milligan, 2007). We also built a website application using the package “shiny” (Chang et al., 2021) that allows individuals to call the simulation functions and perform custom simulations to estimate consequences of management alternatives on horse populations; we describe the shiny application below. Code from our analysis and software for the website application are provided in U.S. Geological Survey (USGS) software releases (Folt, Ekernas, et al., 2023; Folt, Schoenecker, et al., 2023).

RESULTS

Scenario analysis

Population projection of 500 horses under 19 management alternatives over 10 years generated divergent outcomes in population size and metrics related to management effort and cost (Table 2). Predictions from the “No management” alternative resulted in a fivefold increase in population size over a 10-year period (Table 2). Among single-action alternatives with management every three years, the “Mare sterilization” and “GonaCon” scenarios yielded smaller final population size relative to other fertility control alternatives, but no alternative with fertility treatment alone reduced population size to within target population size ranges within 10 years. Rather, “Removals” was the only single-element alternative that reduced population size to within target population size ranges during the projection (Figure 2); it did so by removing, on average, 530 (445–617; 95% CI) individuals from the population over 10 years. However, the predicted total cost of the “Removals” scenario (\$4.73 million; \$3.81–5.51, 95% CI) was substantially higher than other single-action alternatives (Table 2), largely due to costs of unadopted horses being held in captivity for up to 25 years after management is performed on the range. Among the 11 compound alternatives, alternatives involving removals and

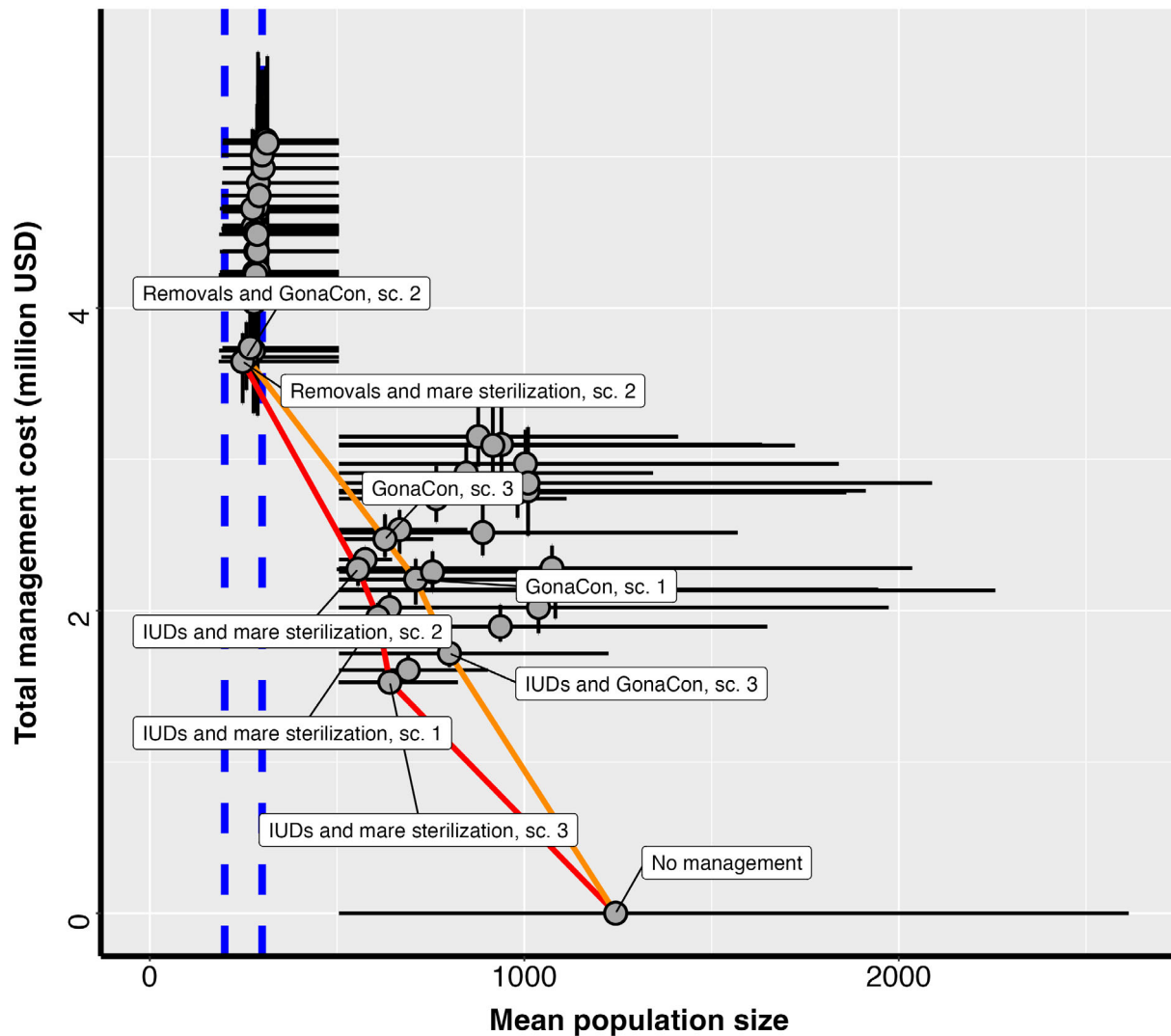

FIGURE 2 The trade-off between predicted mean population size and the total cost of management among 55 management alternatives for a free-roaming horse (*Equus caballus*) population with a starting population size of 500 horses. Points are model-predicted mean estimates with 95% CIs (horizontal and vertical black lines) for alternatives; blue vertical dashed lines indicate the minimum (200 individuals; left) and maximum (300 individuals; right) target population size range for the population (i.e., appropriate management levels). The 55 alternatives include 18 alternatives that were each simulated as three different “scenarios” with prescribed animal capture or treatment at different intervals: 3-year intervals (scenario 1, sc. 1), 2-year intervals (scenario 2, sc. 2), and 4-year intervals (scenario 3, sc. 3). Colored lines are Pareto efficiency frontiers that identify the most cost-efficient alternatives for any outcome in population size (i.e., Pareto optimal alternatives). The red line indicates the Pareto optimal alternatives among the entire set of 55 simulated scenarios; the orange line indicates the Pareto optimal alternatives when alternatives with mare sterilization were excluded. Suboptimal, dominated alternatives are above or to the right of Pareto frontiers. IUDs, intrauterine devices.

one or two forms of fertility control all yielded average population size within target population size ranges over the projection interval, while alternatives involving two forms of fertility control without removals generated populations that exceeded target population size ranges (Table 2). The three scenarios with the lowest mean population size were “Removals and GonaCon” (238 [192–327, 95% CI]), “Removals and mare sterilization” (258 [180–310, 95% CI]), and “Removals with IUDs and GonaCon” (224 [182–323, 95% CI]); however,

“Removals and mare sterilization” required the fewest horses to be gathered, removed, and treated and had the lowest overall management cost among those three scenarios, and the population size did not differ strongly from the other two scenarios (Table 2).

Simulation of 18 management alternatives with animal capture, handling, and treatment at two-, three-, and four-year management return intervals and “No management” allowed us to visualize trade-offs among alternatives varying in both management actions and frequency

(Figure 2, Appendix S1). Removals-only scenarios (e.g., “Removals” every 4 years) required the fewest number of horses to be gathered (838; 783–1046, 95% CI) and treated (0; 0–0, 95% CI) and were relatively inexpensive for management on-range (\$0.72 million; \$0.67–0.90 million, 95% CI). However, removal-only scenarios were relatively expensive off-range (e.g., “Removals” every 4 years cost \$3.52 million off-range [\$2.99–3.92 million, 95% CI] and was the fourth most costly scenario off-range) due to costs associated with horses in long-term holding facilities; those scenarios did not include fertility control treatment that could have reduced reproduction in the population. Two scenarios (“Removals and GonaCon” and “Removals and mare sterilization” every 2 years) each required the fewest number of horses to be removed (312; 312–312, 95% CI), required only a single removal in the first year, and as a consequence were relatively inexpensive off-range (e.g., “Removals and GonaCon” every 2 years was the least-costly off-range scenario [\$2.34 million; \$2.14–2.53 million, 95% CI]). The management scenario that produced the smallest mean population size within target population size ranges and was least-costly overall (the sum of costs both on-range and off-range) was “Removal and mare sterilization” every 2 years, which caused average population size to be 248 (184–505, 95% CI) horses and cost \$3.65 million (\$3.37–3.83 million, 95% CI) in total (Figure 2).

Simulated outcomes of alternatives with management every three years at 10-year and 20-year projection intervals demonstrated that variation in predicted outcomes among alternatives after 10 years propagated over longer projection intervals. Predicted increases in the number of horses gathered, removed, and treated and management costs between 10- and 20-year projection intervals were smaller for “Removals and mare sterilization” than other alternatives that achieved population size within target ranges (Figure 3).

Website application

We built an online website application, *PopEquus*, that hosts the simulation functions within a user interface and allows users to perform custom simulations to estimate the effects of alternative management strategies on wild horse populations in western rangeland ecosystems managed by federal agencies (<https://rconnect.usgs.gov/popequus/>). Two simulation tools are available within the application: one page with a relatively basic interface that can simulate and compare among six single-action alternatives and a “No management” scenario (Basic Tool), and a second page that can simulate and compare

more numerous and complex alternatives, including alternatives with more than one management action (Advanced Tool). Users can specify input values for different variables related to the population, select management alternatives, and then simulate how populations and metrics would be influenced by alternatives. Output metrics are visualized with graphs, a table, and text. We also included an introductory page that frames challenges associated with horse management, a user manual page with explanatory details for how to use the simulation tools, a page that explains the mechanics of the population projections and assumptions during simulations, and a page with exercises that demonstrate how users might use the Advanced Tool to perform simulations to support various decision problems (Appendix S2). For both tools, the user can download reports summarizing simulation inputs and outputs. *PopEquus* provides a flexible tool to estimate the consequences of management alternatives and trade-offs that emerge among them.

DISCUSSION

The management of feral, free-roaming, or wild horse populations is a global issue that is challenged by passionate stakeholders, multiple competing objectives, and complex social–ecological system dynamics (Beever et al., 2018; Folt et al., 2022; Nimmo & Miller, 2007; Scasta, 2019; Scasta et al., 2018). Decision makers around the world can benefit from better understanding trade-offs that exist within horse population management (Converse, 2020), and our results illustrate important trade-offs among competing objectives in horse management. The *PopEquus* application provides decision makers with a tool to identify cost-effective population management alternatives that might manage populations to be within target population size ranges while also minimizing the amount of management performed to achieve desired outcomes. Specifically, among simulated alternatives that reduced population size to within target ranges, management with periodic removals and mare sterilization minimized the number of horses that were handled, removed, and treated and minimized the overall cost of management. This result suggests that mare sterilization could be a useful alternative for achieving multiple objectives. We also demonstrated that shorter intervals between management and/or more effective, longer lasting fertility control methods required fewer horses to be gathered, removed, and treated and decreased management costs compared with longer intervals between management or less-effective fertility control approaches. For this reason, decision makers might benefit from allocating more resources toward shorter management intervals and/or

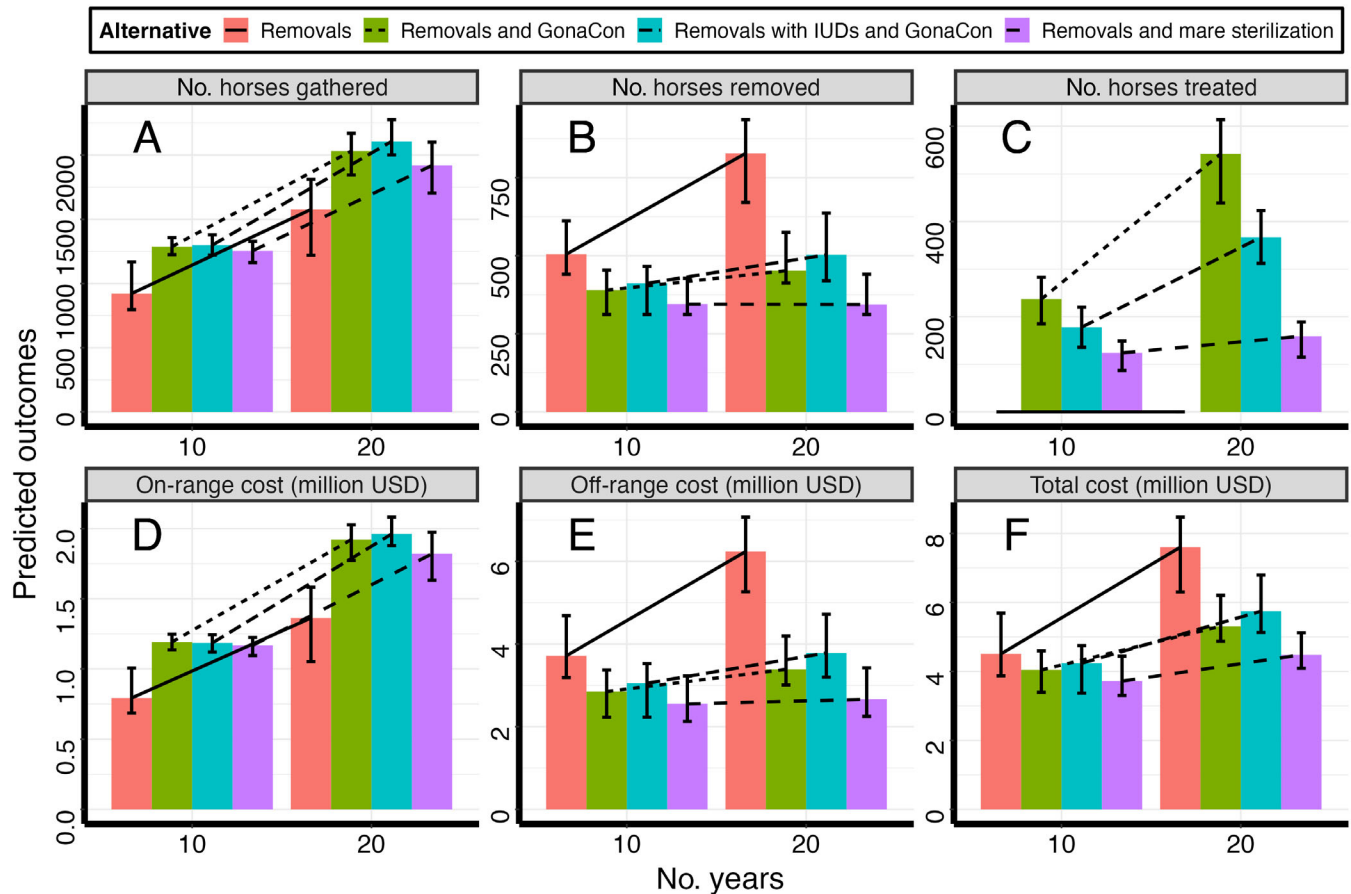

FIGURE 3 Mean estimates (and 95% CIs) for six metrics of free-roaming horse (*Equus caballus*) population management produced by four alternatives (Removals; Removals and GonaCon-Equine [GonaCon] treatment; Removals with intrauterine devices [IUDs] and GonaCon treatment; Removals and mare sterilization treatment) simulated over 10- and 20-year population projection intervals. Horse gather, removal, and fertility control activities were performed in the first year and every third year thereafter (3-year interval) until the end of the projection interval. Metrics are the (A) number of horses gathered, (B) number of horses removed, (C) number of horses treated, (D) cost of gathers and fertility control treatments (on-range cost), (E) cost of animal handling, care, and adoption efforts (off-range cost), and (F) overall cost (total cost). Cost estimates are in millions of US dollars. Ninety-five percent CI was calculated from 50 simulation replicates at both projection intervals.

more effective management in the short term to minimize management effort and costs in the long term. Taken together, our results provide policy makers with information about what management actions could be used and how they can be structured to manage horse populations in ways that maximize ecosystem health and horse welfare while minimizing fiscal costs of management.

Our results indicated that mare sterilization might be a highly effective form of fertility control for reducing horse population growth; however, some horse advocacy groups in the United States have opposed surgical mare sterilization for free-roaming horse populations (Bechert et al., 2022). Other than alternatives with mare sterilization, two alternatives involving removals with GonaCon treatment or removals with both IUDs and GonaCon treatment also performed strongly at reducing population

size and minimizing management metrics compared with other alternatives. Future research might seek to develop and test additional methods for long-lasting fertility control that can be effective with a single handling occasion (Bureau of Land Management, 2021). While our model identifies alternatives that are effective at reducing or maximizing different metrics, the model cannot account for all factors that might be important during management decisions, such as multiple uses of lands, local land use planning considerations, threatened and endangered species' needs, or other important factors. Therefore, the results from simulations, while useful, are unlikely to be the sole basis for site-specific land management decisions.

We compared alternatives under the context of a horse population that exceeded its maximum target population size in year 0 by 66%, a common situation for

BLM-managed populations in the last 10 years, which tends to exceed AML (Bureau of Land Management, 2020; Garrott & Oli, 2013). Our results suggested that, when populations exceed maximum target population sizes, removals are a largely necessary management action to achieve population size within target ranges (Garrott, 2018) and avoid ecosystem degradation. Most North American horse populations occur in expansive rangeland ecosystems where management actions involving animal capture and fertility control treatment are logistically difficult (e.g., difficult access, unapproachable horses, large populations but with low population density, and low capture rates during gathers) and limited or no top-down predators effects on horse populations (Andreasen et al., 2021). With very limited mortality due to predators, fertility control treatment alone (e.g., by darting) might need to be applied repeatedly in populations for many consecutive years to reduce reproduction sufficiently, so that losses to the population by natural mortality exceed gains by reproduction and the population would stabilize in size (e.g., Appendix S2: Figure S9; National Park Service, 2008). Given limited financial and logistical resources (e.g., off-range holding space) available to perform management, decision makers are often only able to perform management with gathers, removals, and fertility control treatment every 3–5 years, such that populations are likely to continue to grow above management-defined population maxima (Garrott, 2018). Excluding alternatives with removals, the fertility-control-only alternative with the lowest mean population size after 10 years was “IUDs and mare sterilization”; however, the 95% CIs for mean population size exceeded the starting population size (500 horses), so even this alternative did not come close to reducing the population to be within the target population size range over 10 years. Therefore, our results suggest that, to achieve population size objectives, at least one removal is needed to reduce populations to within AML, followed by fertility control with frequent application to a large proportion of the female population (e.g., mare sterilization or GonaCon treatment at a two- or three-year return interval) to maintain population stability within AML. If fertility control treatment is less effective, used less frequently, or is less long-lasting, then periodic removals are needed to account for the surplus of births minus deaths to maintain population stability within target population size ranges (Garrott, 2018).

We modeled a relatively broad suite of alternatives, including “No management.” We included “No management” as a baseline comparison of no action but note that horse population management at identified AML population sizes is legally mandated for populations under the jurisdiction of the BLM and

USFS (16 U.S. Code Section 1333). We focused our scenario analysis by making several assumptions based on input from wildlife managers, including assumptions that vaccine treatment would involve gathers, vaccine treatment would be performed by hand, fertility control treatment would be used to treat all females ≥ 1 year old, all age-eligible females would be treated, and for vaccines, a booster shot would be given to all treated individuals after holding until an optimal booster treatment time. However, the website application, *PopEquus*, is a flexible tool that is highly customizable, can simulate specified local population conditions, limitations, and management actions, and can therefore support diverse management decisions (Garrott, 1991). *PopEquus* can simulate populations that differ in population size and sex ratios, logistical constraints on management (e.g., populations that are more or less difficult to capture by gathers or treat by darting), management timeframes (2–20 years), and management actions (adjustable removal settings, booster treatments, vaccine treatment method by darting, costs, etc.). While the primary purpose of *PopEquus* is to support management decisions for individual horse populations (e.g., a single Herd Management Area managed by the BLM or a single Horse Territory managed by the USFS), when settings are adjusted appropriately and a few assumptions are made, the tool also can simulate management of extremely large populations that might occur over large spatial scales or comprise multiple smaller populations (e.g., a BLM horse complex). For example, one can simulate a large regional population (e.g., 10,000 horses) with adjustments to certain variables to reflect limitations in the number of horses that can be gathered, removed, and treated each year when a relatively large number of horses must be managed (Appendix S2: Figure S15). In general, we developed *PopEquus* to support decisions related to wild horse management in the United States, but it could also be used or adapted to understand trade-offs in horse management worldwide, including native horse reintroductions and feral horse management. Because feral and wild burro populations also require management in many places but differ from horses in demographic rates and population structure, future work might revise the modeling framework to include additional simulation capabilities for burros as well.

Our analytical framework estimates the consequences of alternatives on metrics related to ecological costs of horses and horse health (i.e., whether populations are within or exceed management targets that are thought to yield healthy horses and ecosystems), animal handling, and fiscal costs of management. Some have suggested that horse management decisions could benefit from

better understanding stakeholder values and objectives through greater stakeholder engagement, potentially through some form of participatory decision-making (Beever et al., 2018; Folt et al., 2022; National Research Council, 2013), so that decisions are informed by an inclusive and transparent consideration of stakeholder values. For example, structured decision-making (Runge et al., 2020) might help achieve a careful, inclusive, value-focused analysis of a decision problem that might better uncover and explore the full suite of values relevant to different elements of horse management decisions. Such an exercise could use our simulation tool to estimate the consequences of alternatives on value-focused objectives. However, solving multiple-objective decision problems ultimately requires incorporating decision-maker preferences among objectives to identify a solution that strikes a balance among competing objectives (Williams & Kendall, 2017). Future efforts might also revise our model to improve system dynamics, incorporate emerging approaches to fertility control treatment or gathers, account for additional values of decision makers or stakeholders, and incorporate legal requirements or preferences of decision makers as a more explicit decision analysis.

Consistent with predictions about horse population growth (Eberhardt et al., 1982; Garrott & Oli, 2013; National Research Council, 2013), horse populations on federally managed lands in the western United States have increased dramatically over the last decade (Garrott, 2018; Schoenecker et al., 2021), and there are now more than 82,000 wild horses and burros on BLM-managed lands (Bureau of Land Management, 2022). Our scenario analyses and simulation tool can provide informative technical support for decision makers and managers who are mandated to achieve and maintain population sizes within AML, but who also want to minimize cost and animal capture, handling, and care requirements. If the tools provided here are used to identify effective management alternatives at scale, decision makers might be able to “change the course” of free-roaming horse population growth (Garrott & Oli, 2013) and better protect rangelands from the deterioration associated with excessively large horse populations, maintain high-quality habitat conditions for on-range horse welfare, preserve taxpayer resources, and promote a sustainable ecological balance among horses, natural plant and animal communities, and multiple other important land uses pursuant with BLM and USFS mandates.

AUTHOR CONTRIBUTIONS

Brian Folt and Kathryn A. Schoenecker designed the study. Brian Folt, L. Stefan Ekernas, and David R. Edmunds performed statistical analysis, and Brian

Folt and Mark Hannon built the website application. Brian Folt wrote the first draft of the paper, and Kathryn A. Schoenecker and David R. Edmunds contributed critical feedback to manuscript drafts. All the authors gave final approval for publication.

ACKNOWLEDGMENTS

Any use of trade, firm, or product names is for descriptive purposes only and does not imply endorsement by the U.S. Government. We thank S. Rockefeller, B. Smith, and S. King for useful discussions about horse management. We received valuable input from S. Jenkins, P. Griffin, and M. Crabb on versions of the model and website application. We thank P. Giffin, K. Dunham, and two anonymous reviewers for comments that improved the manuscript. This study was supported by funds from the U.S. Bureau of Land Management (Interagency Agreements 4500065781 and L19PG00052) and the U.S. Geological Survey.

CONFLICT OF INTEREST STATEMENT

The authors declare no conflicts of interest.

DATA AVAILABILITY STATEMENT

Code to replicate the analysis was provided by a U.S. Geological Survey software release (Folt, Schoenecker, et al., 2023; <https://doi.org/10.5066/P9HVUA6D>). No original data were analyzed in the paper.

ORCID

Brian Folt  <https://orcid.org/0000-0003-2278-2018>

Kathryn A. Schoenecker  <https://orcid.org/0000-0001-9906-911X>

David R. Edmunds  <https://orcid.org/0000-0002-5212-8271>

REFERENCES

- Andreasen, A. M., K. M. Stewart, W. S. Longland, and J. P. Beckmann. 2021. “Prey Specialization by Cougars on Feral Horses in a Desert Environment.” *The Journal of Wildlife Management* 85: 1104–20.
- Baker, D. L., J. G. Powers, J. I. Ransom, B. E. McCann, M. W. Oehler, J. E. Bruemmer, N. L. Galloway, D. C. Eckery, and T. M. Nett. 2018. “Reimmunization Increases Contraceptive Effectiveness of Gonadotropin-Releasing Hormone Vaccine (GonaCon-Equine) in Free-Ranging Horses (*Equus caballus*): Limitations and Side Effects.” *PLoS One* 13: e0201570.
- Bartholow, J. 2007. “Economic Benefit of Fertility Control in Wild Horse Populations.” *Journal of Wildlife Management* 71: 2811–19.
- Bechert, U., J. W. Turner, Jr., D. L. Baker, D. C. Eckery, J. Bruemmer, C. Lyman, T. Prado, S. King, and M. Fraker. 2022. “Fertility Control Options for Management of Free-Roaming Horse Populations.” *Human-Wildlife Interactions* 16: 1–38.

- Beever, E. A., L. Huntsinger, and S. L. Petersen. 2018. "Conservation Challenges Emerging from Free-Roaming Horse Management: A Vexing Social-Ecological Mismatch." *Biological Conservation* 226: 321–28.
- Berger, J. 1986. *Wild Horses of the Great Basin*. Chicago, IL: University of Chicago Press.
- Bigolin, S., D. J. Fagundes, H. C. Rivoire, A. T. Negrini Fagundes, and A. L. Negrini Fagundes. 2009. "Transcervical Hysteroscopic Sterilization Using Cyanoacrylate: A Long-Term Experimental Study on Sheep." *The Journal of Obstetrics and Gynaecology Research* 35: 1012–18.
- Boyce, P. N., J. D. Hennig, R. K. Brook, and P. D. McLoughlin. 2021. "Causes and Consequences of Lags in Basic and Applied Research into Feral Wildlife Ecology: The Case for Feral Horses." *Basic and Applied Ecology* 53: 154–163.
- Bureau of Land Management. 2010. *Wild Horses and Burros Management Handbook*. Washington, DC: Bureau of Land Management.
- Bureau of Land Management. 2020. "Report to Congress: An Analysis of Achieving a Sustainable Wild Horse and Burro Program." U.S. Department of Interior – Bureau of Land Management. <https://www.blm.gov/sites/blm.gov/files/WHB-Report-2020-NewCover-051920-508.pdf>.
- Bureau of Land Management. 2021. "BLM Wild Horse and Burro Program 2021 Strategic Research Plan." Bureau of Land Management, Department of the Interior. https://www.blm.gov/sites/default/files/docs/2021-11/IB2022-008_att1.pdf.
- Bureau of Land Management. 2022. "Herd Area and Herd Management Area Statistics as of March 1, 2022." https://www.blm.gov/sites/default/files/docs/2022-04/2022_HAHMA_Stats_4.12.2022.pdf.
- Carlisle, C., and D. Adams. 2022. "Enhancing Stakeholder Engagement to Achieve the Sustainable Management of Free-Roaming Equids." *Human–Wildlife Interactions* 16(2). in press.
- Caswell, H. 2001. *Matrix population models*, 2nd ed. Sunderland, MA: Sinauer Associates.
- Chamberlin, J. E. 2006. *How the Horse Has Shaped Civilization*. Toronto, ON: Alfred A. Knopf.
- Chang, W., J. Cheng, J. Allaire, C. Sievert, B. Schloerke, Y. Xie, J. Allen, J. McPherson, A. Dipert, and B. Borges. 2021. "shiny: Web Application Framework for R." R Package Version 1.6.0. <https://CRAN.R-project.org/package=shiny>.
- Coates, P. S., S. T. O'Neil, D. A. Muñoz, I. A. Dwight, and J. C. Tull. 2021. "Sage-Grouse Population Dynamics Are Adversely Affected by Overabundant Feral Horses." *The Journal of Wildlife Management* 85: 1132–49.
- Collins, G. H., and J. W. Kasbohm. 2017. "Population Dynamics and Fertility Control of Feral Horses." *Journal of Wildlife Management* 81: 289–296.
- Converse, S. J. 2020. "Introduction to Multi-Criteria Decision Analysis." In *Structured Decision Making: Case Studies in Natural Resource Management*, edited by M. C. Runge, S. J. Converse, J. E. Lyons, and D. R. Smith, 51–61. Baltimore, MD: Johns Hopkins University Press.
- Côté, S. D., T. P. Rooney, J.-P. Tremblay, C. Dussault, and D. M. Waller. 2004. "Ecological Impacts of Deer Overabundance." *Annual Review of Ecology, Evolution, and Systematics* 35: 113–147.
- Daels, P., and J. Hughes. 1995. "Fertility Control Using Intrauterine Devices: An Alternative for Population Control in Wild Horses." *Theriogenology* 44: 629–639.
- Danvir, R. E. 2018. "Multiple-Use Management of Western U.S. Rangelands: Wild Horses, Wildlife, and Livestock." *Human–Wildlife Interactions* 12: 5–17.
- Davies, K. W., and C. S. Boyd. 2019. "Ecological Effects of Free-Roaming Horses in North American Rangelands." *BioScience* 69: 558–565.
- Dawson, M. J., and J. Hone. 2012. "Demography and Dynamics of Three Wild Horse Populations in the Australian Alps." *Austral Ecology* 37: 97–109.
- de Steiguer, J. D. 2011. *Wild Horses of the West. History and Politics of American Mustangs*. Tucson, AZ: University of Arizona Press.
- Eberhardt, L., A. Majorowicz, and J. Wilcox. 1982. "Apparent Rates of Increase for Two Feral Horse Herds." *Journal of Wildlife Management* 46: 367–374.
- Edwards, G., G. Ellerbrock, R. Eggleston, and M. Ferrer. 2021. "Laser Ablation of the Equine Oviductal Papilla as a Novel Contraceptive Technique." *Clinical Theriogenology* 13: 305.
- Eldridge, D. J., J. Ding, and S. K. Travers. 2020. "Feral Horse Activity Reduces Environmental Quality in Ecosystems Globally." *Biological Conservation* 241: 108367.
- Folt, B., L. S. Ekernas, D. R. Edmunds, M. Hannon, and K. A. Schoenecker. 2023. "PopEquus: A Predictive Modeling Tool to Support Management Decisions for Free-Roaming Horse Populations (Version 1.0.1)." U.S. Geological Survey Software Release. <https://doi.org/10.5066/P9NMRQDG>.
- Folt, B., K. A. Schoenecker, and L. S. Ekernas. 2022. "Multi-Objective Modeling as a Decision-Support Tool for Feral Horse Management." *Human–Wildlife Interactions* 16(2). <https://digitalcommons.usu.edu/hwi/vol16/iss2/7/>.
- Folt, B., K. A. Schoenecker, L. S. Ekernas, D. R. Edmunds, and M. Hannon. 2023. "Scenario Analysis of Management Alternatives for Free-Roaming Horse Populations (Version 1.0.0)." U.S. Geological Survey Software Release. <https://doi.org/10.5066/P9HVUA6D>.
- Garrott, R. A. 1991. "Feral Horse Fertility Control: Potential and Limitations." *Wildlife Society Bulletin* 19: 52–58.
- Garrott, R. A. 2018. "Wild Horse Demography: Implications for Sustainable Management within Economic Constraints." *Human–Wildlife Interactions* 12: 46–57.
- Garrott, R. A., and M. K. Oli. 2013. "A Critical Crossroad for BLM's Wild Horse Program." *Science* 341: 847–48.
- Garrott, R. A., and D. B. Siniff. 1992. "Limitations of Male-Oriented Contraception for Controlling Feral Horse Populations." *Journal of Wildlife Management* 56: 456–464.
- Garrott, R. A., and L. Taylor. 1990. "Dynamics of a Feral Horse Population in Montana." *Journal of Wildlife Management* 54: 603–612.
- Gooch, A. M. J., S. L. Petersen, G. H. Collins, T. S. Smith, B. R. McMillan, and D. L. Eggett. 2017. "The Impact of Feral Horses on Pronghorn Behavior at Water Sources." *Journal of Arid Environments* 138: 38–43.
- Government Accountability Office. 2008. *Effective Long-Term Options Needed to Manage Unadoptable Wild Horses*. Washington, DC: Bureau of Land Management. Report to the Chairman, Committee on Natural Resources, House of Representatives, GAO-09-77.

- Gradil, C., C. Joone, T. Haire, B. Fowler, J. Zinchuk, C. J. Davies, and B. Ball. 2021. "An Intrauterine Device with Potential to Control Fertility in Feral Equids." *Animal Reproduction Science* 231: 106795.
- Gradil, C. M., C. K. Uricchio, and A. Schwarz. 2019. "Self-Assembling Intrauterine Device (Upod) Modulation of the Reproductive Cycle in Mares." *Journal of Equine Veterinary Science* 83: 102690.
- Grange, S., P. Duncan, and J. M. Gaillard. 2009. "Poor Horse Traders: Large Mammals Trade Survival for Reproduction during the Process of Feralization." *Proceedings of the Royal Society B* 276: 1911–19.
- Griffin, P. C., L. S. Ekernas, K. A. Schoenecker, and B. C. Lubow. 2020. "Standard Operating Procedures for Wild Horse and Burro Double-Observer Aerial Surveys." In *U. S. Geological Survey Techniques and Methods*, Book 2, Chapter A16, 76 pp. Reston, VA: U.S. Geological Survey.
- Hall, L. K., R. T. Larsen, R. N. Knight, and B. R. McMillan. 2018. "Feral Horses Influence both Spatial and Temporal Patterns of Water Use by Native Ungulates in a Semi-Arid Environment." *Ecosphere* 19: e02096.
- Hemming, V., A. E. Camaclang, M. S. Adams, M. Burgman, K. Carbeck, J. Carwardine, I. Chades, et al. 2022. "An Introduction to Decision Science for Conservation." *Conservation Biology* 36: e13868.
- Hendrickson, D. A. 2012. "A Review of Equine Laparoscopy." *ISRN Veterinary Science* 2012: 492650.
- Holyoak, G. R., C. C. Lyman, S. Wang, S. S. Germaine, C. O. Anderson, J. M. Baldrighi, N. Vemula, G. B. Rezabek, and A. J. Kane. 2021. "Efficacy of a Y-Design Silastic Elastomer Intrauterine Device as a Horse Contraceptive." *The Journal of Wildlife Management* 85: 1169–74.
- Jenkins, S. H. 2002. *Feral Horse Population Model*. Reno, NV: University of Nevada.
- Kane, A. J. 2018. "A Review of Contemporary Contraceptives and Sterilization Techniques for Feral Horses." *Human-Wildlife Interactions* 12: 111–16.
- Keeney, R., and H. Raiffa. 1993. *Decisions with Multiple Objectives: Preference and Value Tradeoffs*. Cambridge: Cambridge University Press.
- King, S. R. B., K. A. Schoenecker, and M. J. Cole. 2022. "Effect of Adult Male Sterilization on the Behavior and Social Associations of a Feral Polygynous Ungulate: The Horse." *Applied Animal Behaviour Science* 249: 105598.
- Kirkpatrick, J. F., I. M. K. Liu, J. W. Turner, Jr., R. Naugle, and R. Keiper. 1992. "Long-Term Effects of Porcine Zonae Pellucidae Immunocontraception on Ovarian Function in Feral Horses (*Equus caballus*)." *Journal of Reproduction and Fertility* 94: 437–444.
- Kirkpatrick, J. F., and A. Turner. 2007. "Immunocontraception and Increased Longevity in Equids." *Zoo Biology* 26: 237–244.
- Kirkpatrick, J. F., and A. Turner. 2008. "Achieving Population Goals in a Long-Lived Wildlife Species (*Equus caballus*) with Contraception." *Wildlife Research* 35: 513–19.
- Kirkpatrick, J. F., and J. W. Turner, Jr. 1985. "Chemical Fertility Control and Wildlife Management." *Bioscience* 35: 485–491.
- Leslie, P. H. 1945. "On the Use of Matrices in Certain Population Mathematics." *Biometrika* 33: 183–212.
- Levy, J. K., D. W. Gale, and L. A. Gale. 2003. "Evaluation of the Effect of a Long-Term Trap-Neuter-Return and Adoption Program on a Free-Roaming Cat Population." *Journal of the American Veterinary Medical Association* 222: 42–46.
- Longcore, T., C. Rich, and L. M. Sullivan. 2009. "Critical Assessment of Claims Regarding Management of Feral Cats by Trap-Neuter-Return." *Conservation Biology* 23: 887–894.
- Lotka, A. 1907. "Relation between Birth Rates and Death Rates." *Science* 26: 21–22.
- Lubow, B. C., and J. I. Ransom. 2009. "Validating Aerial Photographic Mark-Recapture for Naturally Marked Feral Horses." *Journal of Wildlife Management* 73: 1420–29.
- Lubow, B. C., and J. I. Ransom. 2016. "Practical Bias Correction in Aerial Surveys of Large Mammals: Validation of Hybrid Double-Observer with Sightability Method against Known Abundance of Feral Horse (*Equus caballus*) Populations." *PLoS One* 11: e0154902.
- Lyons, J. E. 2020. "Introduction to Resource Allocation." In *Structured Decision Making: Case Studies in Natural Resource Management*, edited by M. C. Runge, S. J. Converse, J. E. Lyons, and D. R. Smith, 99–107. Baltimore, MD: Johns Hopkins University Press.
- Morris, W. F., and D. F. Doak. 2002. *Quantitative Conservation Biology: Theory and Practice of Population Viability Analysis*. Sunderland, MA: Sinauer Associates, Inc.
- National Environmental Policy Act. 1970. "Public Law 91-190." *U.S. Statutes at Large* 83: 852–56.
- National Park Service. 2008. "Environmental Assessment of Alternatives for Managing the Feral Horses of Assateague Island National Seashore." <https://parkplanning.nps.gov/document.cfm?parkID=207&projectID=17228&documentID=23338>.
- National Research Council. 2013. *Using Science to Improve the BLM Wild Horse and Burro Program: A Way Forward*. Washington, DC: National Academies Press.
- Nimmo, D. G., and K. K. Miller. 2007. "Ecological and Human Dimensions of Management of Feral Horses in Australia: A Review." *Wildlife Research* 34: 408–417.
- Nimmo, D. G., K. K. Miller, and R. Adams. 2007. "Managing Feral Horses in Victoria: A Study of Community Attitudes and Perceptions." *Ecological Management & Restoration* 8: 237–241.
- Núñez, C. M. V., J. S. Adelman, H. A. Carr, C. M. Alvarez, and D. I. Rubenstein. 2017. "Lingering Effects of Contraception Management on Feral Mare (*Equus caballus*) Fertility and Social Behavior." *Conservation Physiology* 5: 1–11.
- Olsen, S. 2016. "The Roles of Humans in Horse Distribution through Time." In *Wild Equids: Ecology, Management, and Conservation*, edited by J. I. Ransom and P. Kaczensky, 105–120. Baltimore, MD: Johns Hopkins University Press.
- Prado, T., and J. Schumacher. 2017. "How to Perform Ovariectomy through a Colpotomy." *Equine Veterinary Education* 31: 209–213.
- Price, E. O. 1984. "Behavior Aspects of Animal Domestication." *The Quarterly Review of Biology* 59: 1–32.
- R Core Team. 2021. *R: A Language and Environment for Statistical Computing*. Vienna: R Foundation for Statistical Computing.
- Ransom, J. I., L. Lagos, H. Hrabar, H. Nowzari, D. Usukhjargal, and N. Spasskaya. 2016. "Wild and Feral Equid Population

- Dynamics." In *Wild Equids; Ecology, Management and Conservation*, edited by J. I. Ransom and P. Kaczensky, 68–86. Baltimore, MD: Johns Hopkins University Press.
- Rodgerson, D. H., and D. A. Loesch. 2011. "Ovariectomy." In *Equine Reproduction*, edited by A. O. McKinnon, E. L. Squires, W. E. Vaala, and D. D. Varner, 2564–73. Oxford: Wiley-Blackwell.
- Roelle, J., F. J. Singer, L. C. Zeigenfuss, J. I. Ransom, L. Coates-Markle, and K. A. Schoenecker. 2010. *Demography of the Pryor Mountain Wild Horses, 1993–2007*. Reston, VA: U.S. Geological Survey.
- Rubin, E. S., D. Conrad, A. S. Jones, and J. J. Hervert. 2021. "Feral Equids' Varied Effects on Ecosystems." *Science* 373: 927.
- Runge, M. C. 2020. "Allocating Funds under the National Fish Habitat Action Plan." In *Structured Decision Making: Case Studies in Natural Resource Management*, edited by M. C. Runge, S. J. Converse, J. E. Lyons, and D. R. Smith, 23–35. Baltimore, MD: Johns Hopkins University Press.
- Runge, M. C., S. J. Converse, J. E. Lyons, and D. R. Smith. 2020. *Structured Decision Making: Case Studies in Natural Resource Management*. Baltimore, MD: Johns Hopkins University Press.
- Rutberg, A., K. Grams, J. W. Turner, Jr., and H. Hopkins. 2017. "Contraceptive Efficacy of Priming and Boosting Doses of Controlled-Release PZP in Wild Horses." *Wildlife Research* 44: 174–181.
- Scasta, J. D. 2019. "Why Are Humans So Emotional about Feral Horses? A Spatiotemporal Review of the Psycho-Ecological Evidence with Global Implications." *Geoforum* 103: 171–75.
- Scasta, J. D. 2020. "Mortality and Operational Attributes Relative to Feral Horse and Burro Capture Techniques Based on Publicly Available Data from 2010-2019." *Journal of Equine Veterinary Science* 86: 102893.
- Scasta, J. D., J. D. Hennig, and J. L. Beck. 2018. "Framing Contemporary U.S. Wild Horse and Burro Management Processes in a Dynamic Ecological, Sociological, and Political Environment." *Human-Wildlife Interactions* 12: 31–45.
- Schoenecker, K. A., S. R. B. King, and T. A. Messmer. 2021. "The Wildlife Profession's Duty in Achieving Science-Based Sustainable Management of Free-Roaming Equids." *The Journal of Wildlife Management* 85: 1057–61.
- Scully, C. M., R. L. Lee, L. Pielstick, J. Medlock, K. M. Patton, G. H. Collins, and M. A. Kutzler. 2015. "Comparison of Chemical and Surgical Vasectomy on Testicular Activity in Free-Roaming Horses (*Equus caballus*)." *Journal of Zoo and Wildlife Medicine* 46: 815–824.
- Simberloff, D., I. M. Parker, and P. M. Windle. 2005. "Introduced Species Policy, Management, and Future Research Needs." *Frontiers in Ecology and the Environment* 3: 12–20.
- Smith, J. T. 2010. "Wild Horses and BLM Management Issues: What to Do with 30,000 Symbols of the American West." *Human-Wildlife Interactions* 4: 7–11.
- Stubben, C. J., and B. G. Milligan. 2007. "Estimating and Analyzing Demographic Models Using the popbio Package in R." *Journal of Statistical Software* 22: 11.
- Symanski, R. 1996. "Dances with Horses: Lessons Learned from the Environmental Fringe." *Conservation Biology* 10: 708–712.
- The Wildlife Society. 2020. *TWS Issue Statement: Feral Horses and Burros in North America*. Bethesda, MD: The Wildlife Society. <https://wildlife.org/tws-issue-statement-feral-horses-and-burros-in-north-america/>.
- Turner, J. W., I. K. M. Liu, D. R. Flanagan, A. T. Rutberg, and J. F. Kirkpatrick. 2007. "Immunocontraception in Wild Horses: One Inoculation Provides Two Years of Infertility." *Journal of Wildlife Management* 71: 662–67.
- Turner, J. W., Jr., I. K. M. Liu, A. T. Rutberg, and J. F. Kirkpatrick. 1997. "Immunocontraception Limits Foal Production in Free-Roaming Feral Horses in Nevada." *Journal of Wildlife Management* 61: 873–880.
- U.S. Congress. 1971. *Wild and Free-Roaming Horses and Burros Act*, 649–651. Washington, DC: U.S. Congress. 92-195.
- Wagman, B., and L. McCurdy. 2011. "A National Injustice: The Federal Government's Systematic Removal and Eradication of an American Icon." *Ecology Law Currents* 38: 8–16.
- Williams, P. J., and W. L. Kendall. 2017. "A Guide to Multi-Objective Optimization for Ecological Problems with an Application to Cackling Goose Management." *Ecological Modelling* 343: 54–67.

SUPPORTING INFORMATION

Additional supporting information can be found online in the Supporting Information section at the end of this article.

How to cite this article: Folt, Brian, Kathryn A. Schoenecker, L. Stefan Ekernas, David R. Edmunds, and Mark Hannon. 2023. "PopEquus: A Predictive Modeling Tool to Support Management Decisions for Free-Roaming Horse Populations." *Ecosphere* 14(9): e4632. <https://doi.org/10.1002/ecs2.4632>